

# E-Link Installation

# E-Link Installation

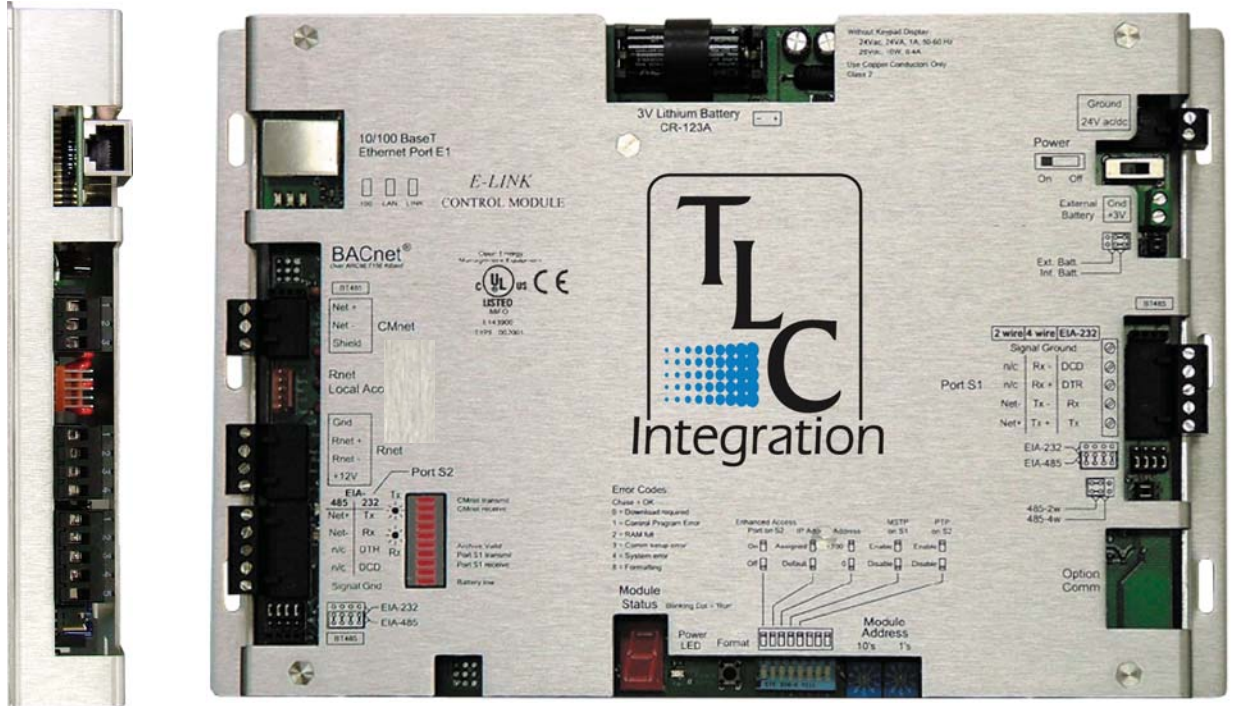

### ATTENTION

This section serves as a notice of the immediate or potential dangers involved when working with the equipment described throughout this manual. Any person involved in installation, maintenance, or service of the equipment should first carefully examine the equipment and read the instructions contained in this manual to ensure that personal and/or equipment injury is avoided.

The following safety messages are used throughout this manual to alert of immediate or potential danger to life or property:



**Hint** Indicates a tip or trick to help you.



**Note** Indicates an important note.



**DANGER!** Indicates an immediately hazardous situation which, if not avoided, will result in death or serious injury.



**WARNING!** Indicates a potentially hazardous situation which, if not avoided, can result in death or serious injury.



**CAUTION:** Indicates a potentially hazardous situation which, if not avoided, can result in minor or moderate injury.

**CAUTION:** Used without the safety alert symbol, indicates a potentially hazardous situation which, if not avoided, can result in personal or property damage. Failure to comply with proper handling of the Turnkey Lighting Control products may void your warranty



In addition, this symbol may appear in the margin of specific portions of text as a safety reminder. Applicable instruction steps will be listed beneath the symbol.

### DISCLAIMER

This equipment has been tested and found to comply with the limits for a Class A digital device, pursuant to part 15 of the FCC Rules. These limits are designated to provide reasonable protection against harmful interference when the equipment is operated in a commercial environment. This equipment generates, uses, and can radiate radio frequency energy and, if not installed and used in accordance with the instruction manual, may cause harmful interference to radio communications. Operation of this equipment in a residential area is likely to cause harmful interference, in which case the user will be required to correct the interference at his own expense.

Instructions contained in this user's guide should be performed only by qualified persons in accordance with local and national codes. Turnkey Lighting Control® Lighting and its affiliates assume no responsibility for any consequences related to the improper use of this manual.



## E-Link Installation Guide

<i>Introduction</i> .....	4
<i>Mounting the E-Link</i> .....	5
<b>Mounting</b> .....	5
<b>Addressing</b> .....	6
<i>Wiring the E-Link</i> .....	6
<b>Network communications</b> .....	6
Turnkey Lighting Control Network .....	6
BACnet over MS/TP .....	6
BACnet over PTP .....	6
Baud Rates on Ports S1 and S2 .....	7
BACnet IP and BACnet over Ethernet .....	7
<b>Network Topologies</b> .....	7
BACnet over Ethernet & BACnet IP .....	8
BACnet over MS/TP .....	8
<b>Network Wiring</b> .....	9
EIA-232 Wiring .....	9
EIA-485 (2-wire) Wiring .....	9
EIA-485 (4-wire) or EIA-422 (4-wire) Wiring .....	9
ARCNET Wiring .....	9
<b>Power Wiring</b> .....	10
<b>Troubleshooting</b> .....	10
LEDs .....	10
Protection .....	10
Production Date .....	10
Formatting the Control Module .....	10



### Introduction

This document provides instructions on how to install the E-Link in two main steps: mounting and wiring. The majority of the document is devoted to wiring the E-Link in the context of BACnet and Modbus networks and protocols. The intended audience for this installation guide is electrical contractors and other technicians, such as BAS technicians certified to handle low voltage electronics and wiring. The E-Link module; though sophisticated in its operation, is simple to install because all programming and configuration of the E-Link is performed by Turnkey Lighting Control technicians before shipment.

The E-Link is a controller and protocol translator used to integrate devices on a Turnkey Lighting Control network with a BACnet or Modbus Building Automation System network. The E-Link enables the BAS to effectively monitor the status of and control any point on the Turnkey Lighting Control network.

The Turnkey Lighting Control network includes devices that communicate through the Turnkey Lighting Control open protocol across the 2-wire RS-485 connection. The devices may include RCS1000 series, L26 series, L28 series, L35 series, and Qwik-Kit series conversion kits.

The E-Link supports the following BACnet protocols: BACnet IP, BACnet over Ethernet, BACnet over MS/TP, BACnet over PTP, and BACnet over ARCNET (156K).

The E-Link supports the following Modbus protocols: Modbus RTU and Modbus ASCII.

Refer to Figure 1 on page 5 for E-Link layout and dimensions.

## Mounting the E-Link

### Mounting

Screw the control module into an enclosed panel using the mounting holes provided. Be sure to leave about 2 inches (5 centimeters) on each side for wiring. Refer to Figure 1 below for mounting holes and dimensions.

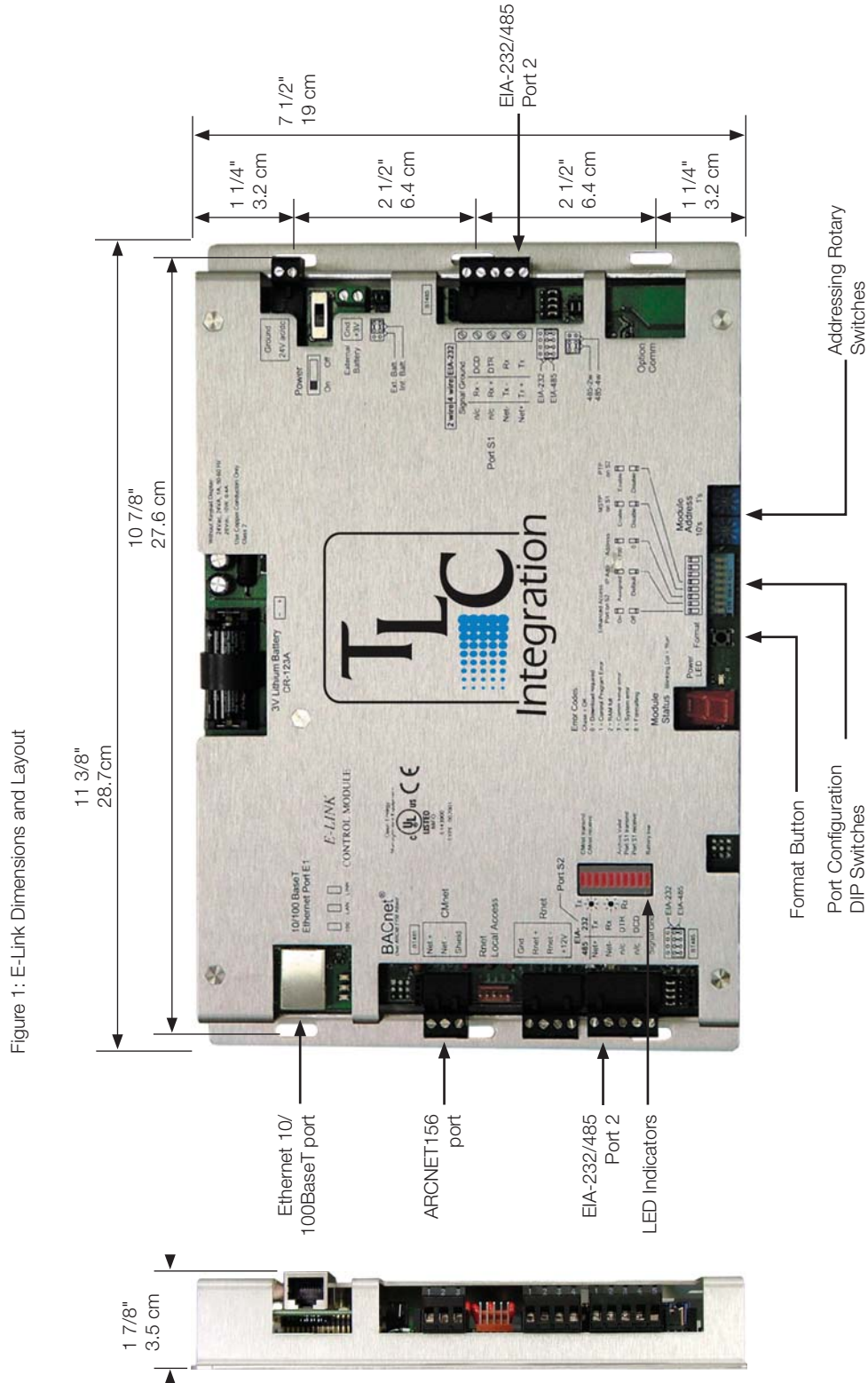

### Addressing

Note: Addressing the E-Link as described here is necessary only if you have been requested to do so by Turnkey Lighting Control technical support for troubleshooting purposes.

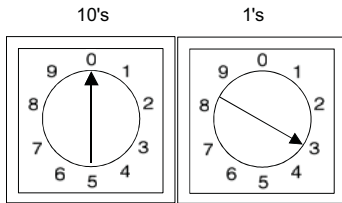

Figure 2: Setting the E-Link Control Module's Address

The E-Link module only reads the address when the control module is first turned on. A change of address on rotary switches will not be read until the module is restarted. The control module has two rotary switches for addressing. One switch corresponds to the tens digit and the other corresponds to the ones digit. For example, if the control module's address is three, set the Tens switch to zero and the Ones switch to three, as shown in Figure 2.

### Network communications

### Wiring the E-Link

#### Turnkey Lighting Control Network

The Turnkey Lighting Control E-Link communicates with the Turnkey Lighting Control panels using a 2-wire twisted pair EIA-485 connection on port S2 or S1 of the E-Link. Port S2 should be used to connect Turnkey Lighting Control network unless you are communicating to the E-Link via BACnet over PTP (discussed below). Ports S2 and S1 have communications jumpers that must be set for 2-wire EIA-485 mode when connecting the Turnkey Lighting Control network wires to either of these ports. Refer to Table 1 and Figure 1 for port and jumper locations on the Turnkey Lighting Control E-Link.

Once the Turnkey Lighting Control E-Link is connected to the first Turnkey Lighting Control panel, additional Turnkey Lighting Control panels may be connected in series using a daisy chain topology. Refer to Turnkey Lighting Control's "LP Controller User Guide" for details on addressing the Turnkey Lighting Control panels.

#### BACnet over MS/TP

The E-Link can connect the BACnet devices communicating by MS/TP only through port S1. MS/TP requires 2-wire EIA-485. Refer to "EIA-485 (2 wire) Wiring" for wiring instructions. Port S1 jumpers must be set to EIA-485 mode, and 2-wire mode.

Figure 3: DIP Switch Settings

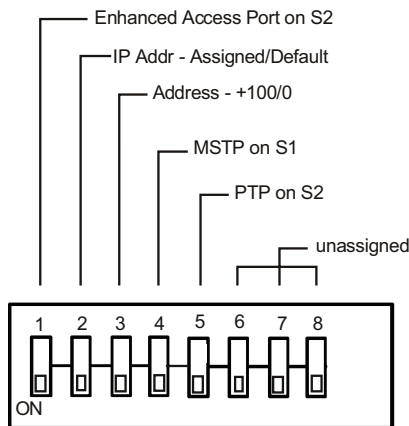

### Baud Rates on Ports S1 and S2

The E-Link can connect to Turnkey Lighting Control panels through the S1 or S2 port at 9600 bps. It can connect to BACnet devices through the S1 port at 9600 bps, 19.2 kbps, 38.4 kbps, or 76.8 kbps, communicating by MS/TP (DIP switch 4), or Modbus. It can connect to BACnet devices at through the S2 port at 9600bps, 19.2 kbps, or 38.4 kbps, communicating by PTP or Modbus. Communication Baud rates for S1 and S2 ports are factory set using the setup menu. Refer to Figure 3 below for DIP switch settings.



**Note** Baud Rate can be changed in the field with an IP-Cable.

### BACnet IP and BACnet over Ethernet

The E-Link can connect to an Ethernet network by using a LAN 10base-T cable to connect to the 10/100 BaseT Ethernet port. The 10/100BaseT Ethernet port automatically detects whether the connection speed is 10 or 100 mbps. For BACnet IP and BACnet over Ethernet communications use Port E1.



**Note** IP Address change cable can be used to change IP Address in the field.

### Network Topologies

When connecting wires to the E-Link be sure to follow these general steps:

1. Make sure the control module's power is off before wiring it to the network.
2. Check the network communication wiring for shorts and grounds.

The following diagrams show network topologies for each of the BACnet protocols and Modbus. Use these diagrams in conjunction with Table 1 to wire the E-Link.

### EIA-485 (2-wire) Wiring

When connecting the E-Link module to a device that speaks 2-wire EIA-485, the recommended cabling to use is shielded, 18-24AWG twisted pair.

The distance from the E-Link to the first EIA-485 device depends on the communications baud rate; on average, the distance should not exceed 3,000 feet (914.4 meters) at 9600 baud. Keep in mind the repeaters are often required:

- after connecting 32 EIA-485 devices
- when using long runs of wire

For EIA-485 (2-wire) configurations on Port S2 note that the Port S2 configuration jumper must be set to EIA-485. For EIA-485 (2-wire) configurations on Port S1, note that the Port S1 configuration jumpers must be set to EIA-485 and EIA-485 2-wire. See Figure 10a for 2-wire EIA-485 wiring using Port S2. Figure 10b shows 2-wire EIA-485 on Port S1.



# Turnkey Lighting Control Component: E-LINK Installation Guide

## BACnet over Ethernet & BACnet IP

(used to connect to Carrier One Company BCU)

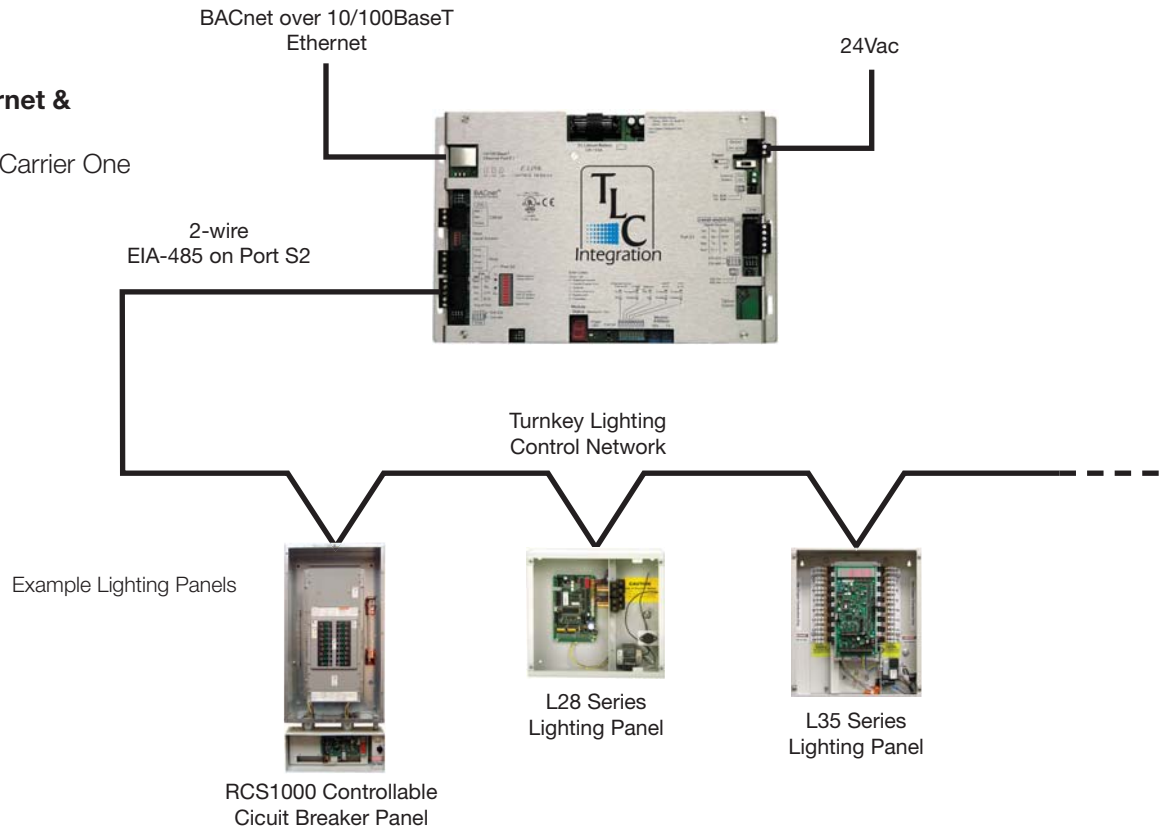

## BACnet over MS/TP

(used to connect to ALERTON Technologies and other MS/TP systems)

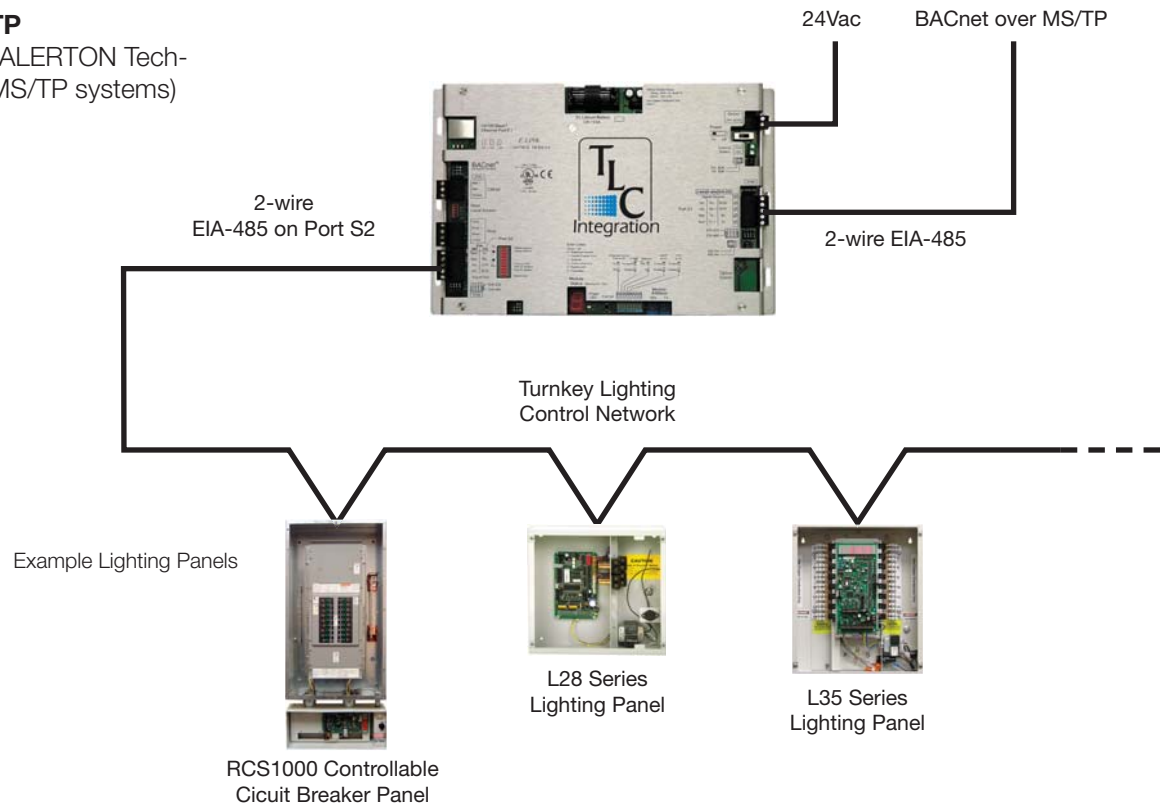

### Power Wiring

**CAUTION** The control module is a Class 2 device (less than 30 Vac, 100 Va maximum). Take appropriate isolation measures when mounting the control module in a control panel where non-Class 2 devices (for example, 120 Vac) or wiring are present. The control module's operating range is 21.6 Vac to 26.4 Vac. If voltage measured at the control module's power input terminals is outside this range, the control module may not work properly.

1. Make sure that the control module's address is set and the power switch is off.
2. Make sure the 24 Vac power source is off.
3. Pull the terminal plug from the control module's power terminals labeled Gnd and 24 Vac.
4. Connect the transformer to the terminal plug.
5. Apply power to the transformer.
6. Make sure that 24 Vac is present at the terminal plug.
7. Insert the terminal plug into the control module's power terminals labeled Gnd and 24 Vac.
8. Turn on the control module's power switch.

When the control module turns on, the Run LED begins blinking. The alphanumeric display shows a chase pattern if the control module is running with no errors.

You can verify that the E-Link control module is communicating on the CMnet by making sure the CMnet transmit and receive LEDs are active.

Figure 10b: 2-wire EIA-485 wiring on Port S1

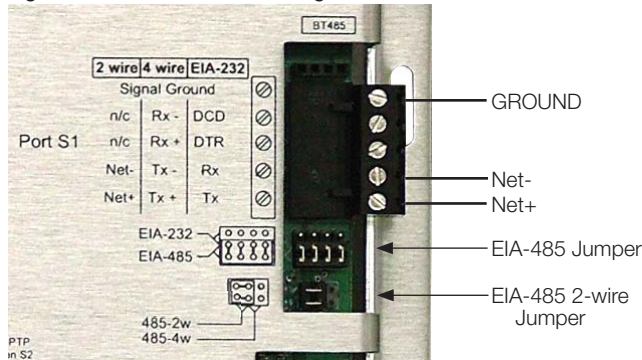
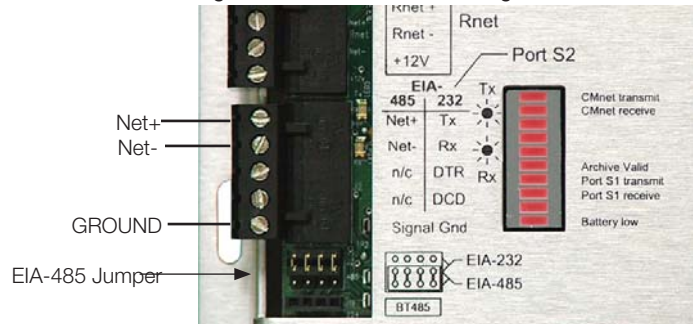

Figure 10a: 2-wire EIA-485 wiring on Port S2



### Trouble Shooting

#### LEDs

The E-Link control module has several status LED indicators to assist with troubleshooting. The control module status LED displays alphanumeric numbers that are described on the control module. The Ethernet port LEDs display the link, status, and speed. The other LEDs indicate the following states:

- Power** - lights when power is being supplied to the control module.
- CMnet receive** - lights when the control module receives data from the CMnet.
- CMnet transmit** - lights when the control module transmits data over the CMnet.
- Archive Valid** - lights when backup is valid.
- Port S1 transmit** - lights when the control module transmits data from Port S1.
- Port S1 receive** - lights when the control module receives data in to Port S1.
- Battery low** - lights when the battery is low.

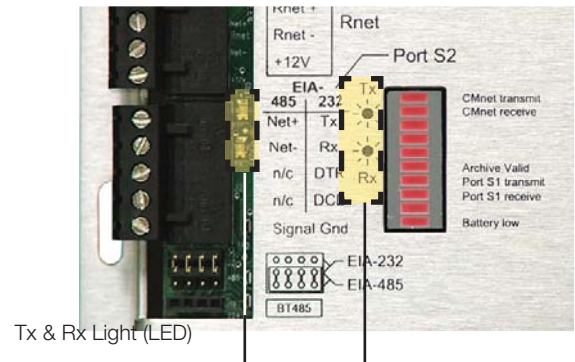

#### Protection

The E-Link control module is protected by internal solid state Polyswitches on the incoming power and network connections. These Polyswitches are not replaceable and will reset themselves if the condition that caused the fault returns to normal.

- Power protection** - metal oxide varistor, solid state fuses, and capacitors.
- Network protection** - solid state fuses, transient voltage suppressors, 50 V isolation.
- Analog Input protection** - metal oxide varistor, series resistor, solid state overvoltage protection, capacitor.
- Analog Output protection** - metal oxide varistor, series resistor.
- Relay Output protection** - metal oxide varistor, relay isolation.

The following two sections are for WebCTRL users only.

#### Production Date

To determine when a control module was manufactured, check the module status report for the control module in WebCTRL. Refer to WebCTRL Help for more information about the module status report.

A sticker on the back of the control module also shows the date the control module was manufactured. The first three characters on the sticker indicate the type of control module. The next two characters show the year and month of manufacture.

#### Formatting the Control Module

Since formatting the control module erases all memory, you need to use WebCTRL to transfer memory back to the control module after it is formatted. **Do not format the module if you do not have WebCTRL software.**

**NOTE** Since the control module is automatically formatted when you transfer memory, you should only manually format the control module if communication was not established after the memory transfer.

1. Press and hold the Format button, then turn on the control module's power.
2. Continue to hold down the Format button until 8 is displayed, then 0.
3. Release the Format button.
4. Transfer memory to the control module. Refer to WebCTRL Help for more information.